

Basement Finishing Guide



Village of Round Lake Building Department

442 N. Cedar Lake Rd., Round Lake, IL 60073 Ph. 847-546-0963 Fax 847-546-5405 www.eroundlake.com

Scope

The Round Lake Building Department understands reading and applying building codes can be difficult and cumbersome to a homeowner. The information in this guide is intended to help the do-it-yourself homeowner navigate through the permit, review and inspection process of remodeling a basement into a finished habitable space. The information provided in this publication is based upon the building codes adopted by the Village of Round Lake. This guide covers the general requirements and is not intended to be a prescriptive publication. Additionally, there may be exceptions to some codes described in here. Do-it yourselfers are encouraged to obtain design information from reputable publications or design professionals. Although we cannot help design your project, our staff will be more than happy to assist you with your project in any way we can.

Process

Permits

Building permits help assure that your home is safe from structural failure, fire hazards from electrical and heating systems, electrical shock, and health risks. Building permits provide a permanent record of the work performed and inspections conducted on the project.

Homeowners are responsible for obtaining the building permit to finish or remodel a basement that involves construction of walls or installation or extension of electrical circuits, plumbing systems, or ductwork. A homeowner may authorize a contractor or agent to obtain the building permit. Building permits for a basement finishing project become invalid unless the work authorized by such permit is commenced within 180 days after it is issued, or if the work authorized by the permit is suspended or abandoned for a period of 180 days. A project is considered to be suspended or abandoned if no inspections have been approved during a 180 day period.

No change to the approved plans is authorized without prior written approval by the code official.

Application and Fees

A permit application is required prior to the review process. The application can be obtained on-line at www.eroundlake.com or at the Round Lake Village Hall. Fees are assessed based upon the cost and scope of work proposed. All fees are due upon approval of the permit. In addition to the permit fees, a refundable \$250 cash bond is required for basement finishing projects. Cash bonds are normally refunded within 3 weeks of the final approved project.

Codes

The Village of Round Lake codes for residential basements include the 2006 International Code, the 2005 National Electrical Code, the 2009 International Energy Conservation Code and the latest Illinois State Plumbing Code. Amendments to these codes apply and are referenced throughout this guide.

Contractors & Insurance

Contractors and subcontractors are required to submit contact information and required licenses (generally plumbing and electrical) and insurance. Not all contractors are required to provide proof of insurance to the Village of Round Lake. Homeowners are strongly encouraged to protect themselves and request proof of liability insurance from contractors and subcontractors providing services on the premises.

Construction Plans

- Two sets of plans, including plan view (see fig.8) and wall detail (see fig.1), drawn to scale(1/4 inch or 1/8 inch equals 1 foot is preferred) are required to be submitted with the application. Plans must provide with sufficient clarity and detail dimensions to show the nature of the work to be performed. The plans must show the size and type of materials to be used. A third set is required if plumbing work to be done. Plumbing plans must be described with a diagram or isometric drawing. *See fig. 8 for example of required floor plans and Fig.5 for plumbing plans.*
- The plans must identify and show the location of existing and proposed utilities, plumbing and electrical fixtures, electric panel, exterior windows (including type) and/or doors, receptacles, smoke detector, furnace, walls, stairs and all other pertinent information, as concisely and clearly as possible.
- All new or additional devices such as, but not limited to, furnaces, whirlpool tubs and pre-fabricated fireplaces require the submittal of the manufacturer's installation instructions.
- Electrical panel schedule (list of circuits and number of available slots). See fig.6

Inspections

Inspections at various stages of the work are required as the work progresses. The project is not considered complete until a satisfactory final inspection has been obtained. When the final inspection is approved, the permit is closed and a Certificate of Occupancy will be issued. A 24 hour notice is required for scheduling all inspections. Failure to call for a required inspection is a violation of the permit. The following inspections may be required for a basement remodel.

- **Under slab -plumbing** – Where under-floor plumbing is required, an under-slab inspection is required after the under-floor piping is installed prior to filling the trench and replacing the floor.
- **Rough-in** – This inspection is done before any wiring, plumbing piping, or mechanical ducts in walls and ceilings are covered with insulation, sheet rock, paneling, etc. All piping, ductwork, sub-panels, wiring, junction boxes, and outlet boxes shall be installed.
- **Insulation** – This is inspected after insulation is installed and prior to installing drywall.
- **Drywall** – This inspection is performed after all drywall is fastened and prior to taping.
- **Final** – This inspection is scheduled when, drywall, doors, and all fixtures, receptacles and devices have been installed so the space is ready to occupy and use. Cosmetic items that are not regulated by the building code, such as trim, painting, and other finish work, does not have to be completed to obtain the final inspection.

Planning

It is important to consider code requirements when planning your basement remodeling project. Some of the more common issues to consider are listed below. Please be aware that this is not a comprehensive list.

Bedrooms

Bedrooms must be at least 70 square feet for one person and 100 square feet for two persons.

Bedrooms are required to have direct access to the exterior by way of a window with a net clear area of 5.7 sq. ft. *See Fig. 9.* A separate egress opening for the adjoining area of the basement is not required if there is an egress opening in a basement bedroom. Emergency escape windows are allowed to be installed under decks, provided the location of the deck allows the window to be fully opened, and provides a path not less than 36 inches in height to a yard area.

Hallways and stairways

Hallways and stairways must be provided with at least 36 inches of clear width.

Utility Room and systems

The furnace and water heater must be provided with access that would allow the equipment to be replaced or to be serviced. The manufacturer's instructions will include required clearances on all

sides of the equipment, and other important details that may impact how much space must be maintained around the equipment. Do not plan to build walls that will reduce this required space.

Many components of a house require access for servicing and replacement. Your plans should take into account that this access will be provided. A minimum of 12 inches clear space are required around the water meter and main water shutoff. The sanitary sewer cleanout requires 18 inches of clearance for rodding operations. All electric junction boxes, floor drains, cleanout fittings, backwater valves, gas line unions, and valves for water and gas lines are required to remain accessible.

Construction

Framing

- The basement ceiling shall have a height of not less than seven feet. Exceptions may be granted for beams, pipes or ductwork allowing a clearance of not less than 78 inches.
- Wall sole (bottom) plates not separated by an approved moisture barrier are required to be pressure treated lumber.
- All stud frame walls shall be constructed with a minimum of 2 x 4's, 16 inches on center with at least a single top plate.
- Electrical and plumbing within walls must be protected from physical damage from nails and other objects driven into the studs and joists. Holes bored in joists and studs must be located to provide a minimum 1 ¼ inches of clearance for conduit and plumbing. Where the clearance is less than 1 ¼ inches, the area shall be protected by a 1/16 inch metal plate.

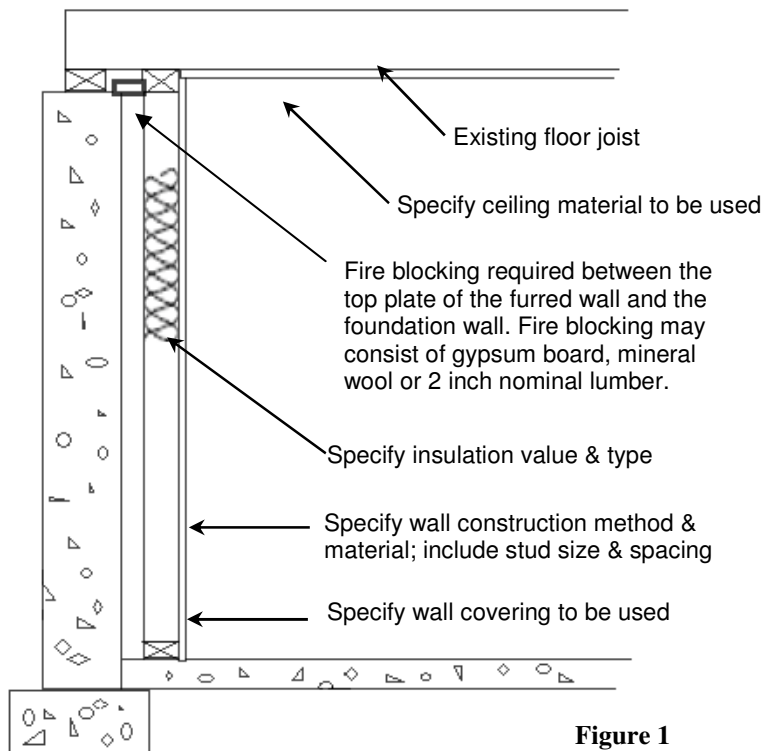

Figure 1

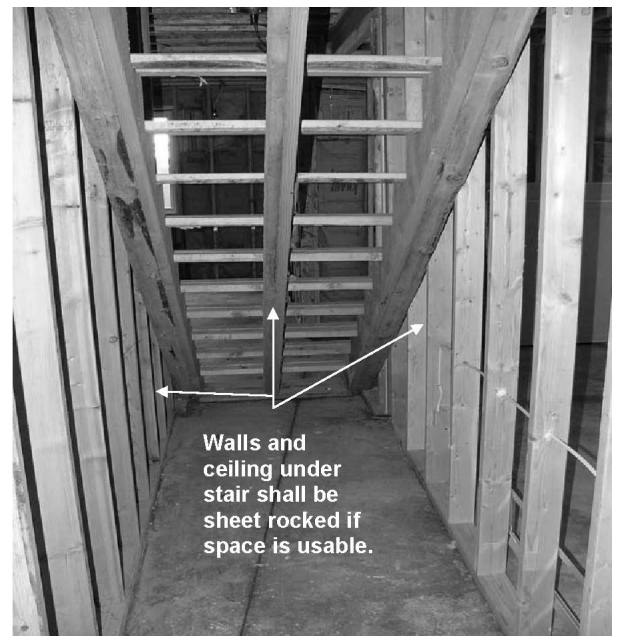

Figure 2

Fireblocking

Fireblocking is a code mandated technique that is intended to slow the spread of fire in a concealed location. Without it, a fire may spread rapidly, using the chimney effect to move up in concealed chases. Fireblocking is typically done with 2 inch thick nominal lumber, ¾ inch plywood, ½ inch gypsum board or rock wool. Fireblocking is required in concealed locations, such as walls, wall/ceiling interconnections with soffits, concealed stairs, and around pipes and other penetrations

at the floor/ceiling level. All penetrations at top plate of wall shall be fire stopped. All concealed spaces shall be fire blocked. *See Fig. 1 and Fig. 7a & 7b*

Enclosed accessible space under stairs shall have the under stair surface protected with ½" gypsum board. *See Fig. 2*

Energy Efficiency and Vapor Barriers

The Illinois Energy Efficiency Code requires basement walls to be insulated. There are two common options for insulating the concrete walls.

- Option 1 Attach R10 foam sheathing directly to the concrete and tape/seal all joints. Frame the wall in front the sheathing.
- Option 2 Frame the wall with a ½ inch air gap between the concrete and the framing. Fill the cavities with R-13 batt insulation.

Kraft faced insulation offers the optimum vapor barrier. All seams should be sealed or overlapped. If polyethylene (plastic sheeting) is used, it should be placed between the concrete and the cavity open faced type insulation. If the foam sheathing option is used, all seams must be taped with the manufacturer's recommended product to provide a continuous vapor barrier.

Wall and Ceiling Covering

- All framed walls are to be covered with a minimum ½ inch gypsum board.
- Gypsum board shall be fastened with nails placed every 8 inches or with screws spaced every 16 inches.
- Gypsum board installed on ceilings shall be fastened with nails spaced every 7 inches or with screws spaced every 12 inches.

Mechanical

- All habitable rooms are required to be able to maintain a minimum 68 degrees measured at 3 feet above the floor; typically this may be accomplished by installing additional heat ducts. Depending on the layout of your basement and heating equipment, a return air duct may be necessary to aid in balancing the heating/cooling load. Return air systems are not allowed from the bathroom.
- If remodel project includes a bathroom, an exhaust fan will be required and must be vented to the exterior of the building. The vent termination must not exhaust any closer than 3 feet from any windows or doors.
- Combustion air must be provided in confined spaces for fuel-burning appliances (gas furnace and water heater). This may need to be addressed if the fuel-burning appliances are partitioned from the open space of the basement unless direct air from outside the building is provided.
- Three feet of service area is required in front of each appliance.
- Appliances are not permitted in sleeping rooms, bath rooms, or storage closets.

Electrical

Electrical equipment and wiring

- A required working clearance of at least 30 inches wide and 36 inches deep in front of the electrical panels must be provided. Electrical panels are required to be accessible so that the cover can be removed and accessed for future wiring needs or repair and maintenance.
- Electric panels are not allowed within closets or bathrooms.
- All circuits must be identified and labeled accordingly in breaker panel box.
- Only one conductor is allowed under each screw of a circuit breaker.
- Electrical wiring is to be run in EMT (often referred to as Conduit). Use of AC (often referred to as Greenfield) and NMC (often referred to as Romex) are not permitted.
- Attach junction boxes to studs so that the plaster ring will end up flush with the finished wall surface.
- The gap between the edge of the junction box ring and the gypsum sheeting shall be no larger than 1/8 inch.

- All junction boxes shall remain accessible and shall not be concealed within walls or ceilings.
- A cover is required for all junction boxes.
- Electrical conductors (wires) are required to be properly color coded. The most common coding is white or gray for the grounded conductor (neutral), green for the equipment grounding conductor, and black or other colors for the ungrounded (hot) conductor.
- The maximum size of breaker to protect the circuit conductors is 15 amps for #14 gauge conductors, 20 amps for #12 gauge conductors, and 30 amps for #10 gauge conductors.

Circuits required

- General lighting – One 15 amp circuit for each 600 square feet of space.
- Bathroom receptacles – One separate 20 amp circuit.
- Laundry area – One separate 20 amp circuit.
- Kitchenettes and bars - Two separate 20 amp circuits.

Electrical Outlets

- General use receptacles along walls shall be provided for all unbroken wall spaces over 2 feet wide; Receptacles shall be located so that no point on the floor line is more than 6 feet, measured horizontally from an outlet. *See fig. 3*
- A 20 Amp within 3 feet of the outside edge of a sink basin. *See fig.4*
- All receptacles shall be the 3 prong grounding type.
- Switches and outlets must be securely fastened to the junction box, and covered with a compatible cover.
- A switched light is required for all rooms. Switched lighting may include one side wall receptacle duplex.
- Stairways, hallways and rooms with more than one door shall have a 3-way or 4-way switch at each entry.
- Ceiling mounted fixtures (except in storage closets and hallways) must be installed using a ceiling fan rated box.
- Closet fixtures shall be fully enclosed, surface or recessed mounted, and positioned at least 12 inches from the nearest point of storage.

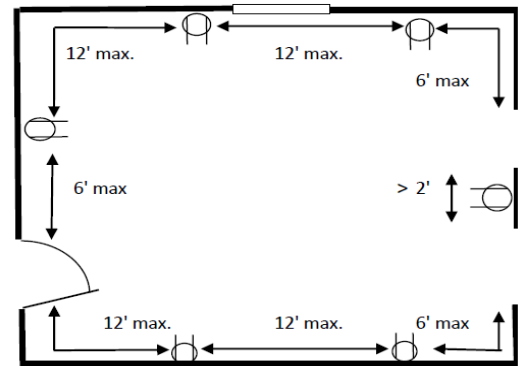

Figure 3

Ground Fault Circuit Interrupters (GFCI)

GFCI protection is required for receptacles in the following locations:

- Bathrooms *See Fig. 4*
- Receptacles serving bar sinks, sinks, kitchen/kitchenette counter tops and islands.
- Unfinished basement areas (areas used as work rooms, storage and mechanical equipment) – Note: Dedicated circuits for a washer, dryer, furnace, sump pump, refrigerator or freezer do not require GFCI protection.

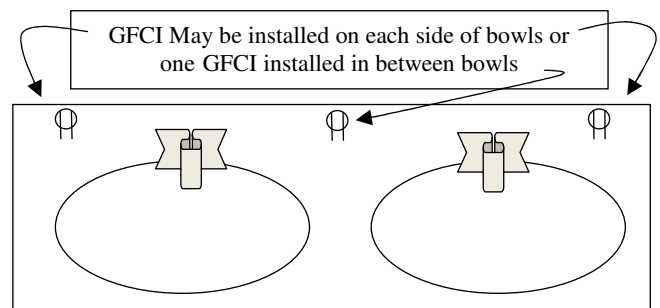

Figure 4

(AFCI) Arc fault circuit interrupter protected outlets

The electrical code requires arc-fault circuit interrupter protection for all electrical outlets located within bedrooms. AFCI protects against arcing that may occur in broken or frayed cords of electrical appliances. AFCI protection is either installed at the circuit breaker or an AFCI outlet is installed on the first receptacle in the series.

Lights showers/tubs

No part of a hanging fixture (i.e. chain, cord) is permitted to be installed within 3 feet of a tub or shower. Other type fixtures installed above or within 3 feet of the tub or shower must be listed for wet locations.

Smoke alarms/Carbon monoxide alarms

- Smoke alarms shall be installed in the following locations:
 - In each sleeping room.
 - Outside each separate sleeping area in the immediate vicinity of the bedrooms.
- All required smoke alarms within an individual dwelling unit shall be interconnected in such a manner that the actuation of one alarm will activate all of the alarms in the individual unit. All required smoke alarms shall be hard wired with battery backup.
- Illinois State law requires a minimum of one carbon monoxide detector per dwelling unit located outside each sleeping area within 15 feet of bedrooms.
- Dwellings without smoke and/or carbon monoxide detectors in existing spaces will be required to install them as a condition of the permit.

Plumbing

All plumbing shall comply with Illinois State Plumbing Code and Village of Round Lake amendments.

- Copper piping and tubing shall be used for all water supplies. Water supply connections to the plumbing fixture may be permitted with a flexible stainless steel connector.
- An individual shutoff valve is required on the fixture supply water pipe to each plumbing fixture other than a bathtub or a shower.
- All shower control valves must be the anti-scald type (pressure balance, thermostatic mixing, or combination pressure balance/thermostatic mixing per ASSE 1016).
- Drainage pipes of 3 inches or less are to be sloped at least 1/4 inch per foot. Drainage pipes larger than 3 inches in diameter require a slope of at least one inch per foot. Be sure to consider the distance your drain lines must travel, and the elevation of the drain line you want to tie into, when planning the location of your plumbing fixtures.
- All plumbing fixtures except toilets require a P-trap drain.
- All drains shall be vented into a vent stack.
- PVC drain waste and vent piping connections must be primed with purple primers prior to cementing connections.
- Access panels must be provided for hydro massage bathtubs and air admittance valves as required by the manufacturer.

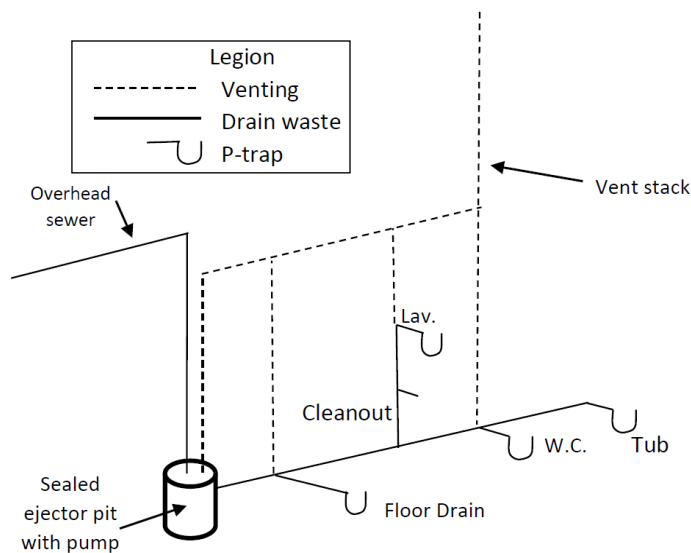

Figure 5

Main	
Kitchen	Dishwasher
Kitchen	Microwave
Dining Rm	Furnace
Bath Rm	Bed Rm 1
Master Bed	Bed rm 2
Garage	Sump
A/C	Open
A/C	Open
Open	Open
Open	Open

Figure 6

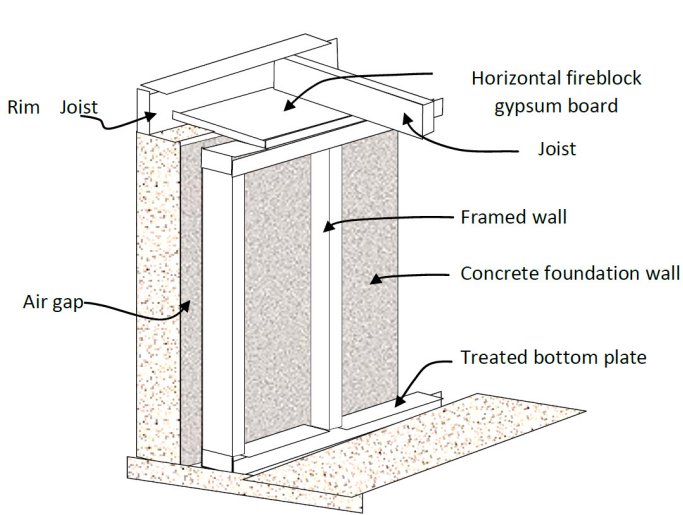

Figure 7a

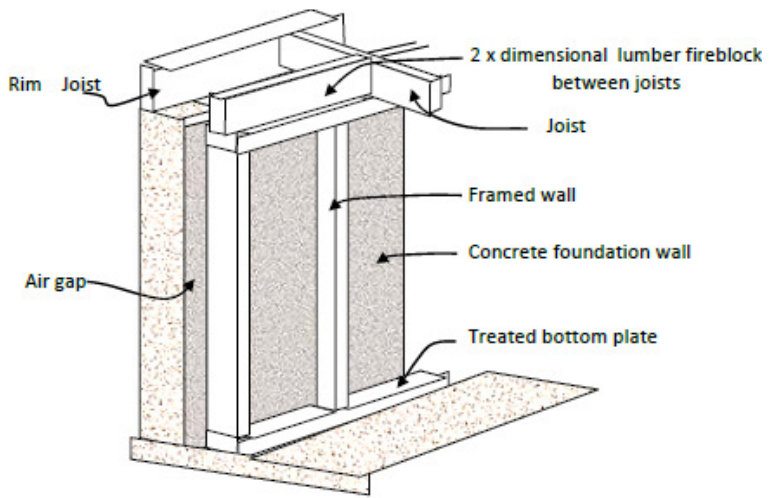

Figure 7b

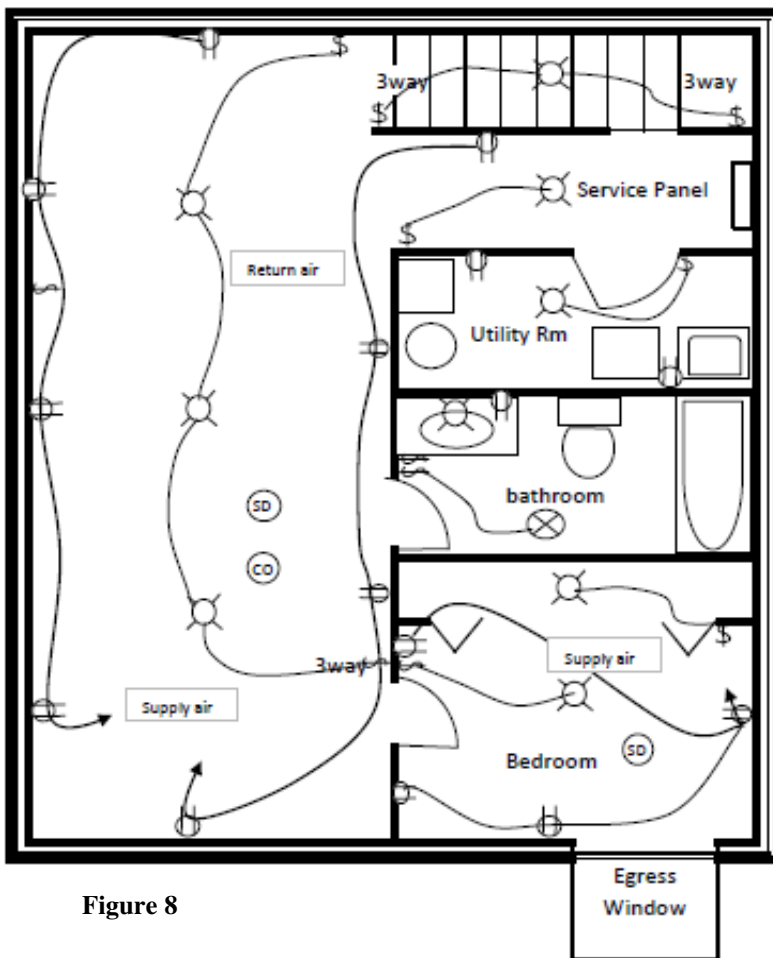

Figure 8

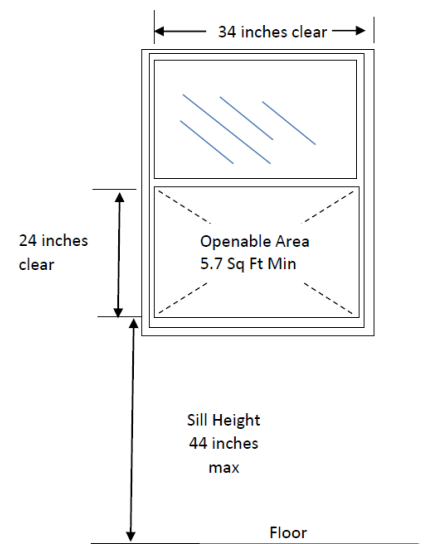

Figure 9

Checklist:

- Completed **application for permit**.
- Two sets of quality drawn **plans**; three sets if plumbing work is proposed.
- One copy of the **electrical panel schedule**. Schedule should include available slots.
- One set of **installation instructions** for the following: furnace and air conditioner, whirlpool tub, prefab fireplace and water heater.
- One copy of the **electrical contractor's license and certificate of liability insurance**, if applicable (unless the homeowner is doing the work).
- One copy of the **plumbing contractor's license and certificate of liability insurance**, if applicable (unless the homeowner is doing the work).
- One copy of the **plumber's license**, if applicable (unless the homeowner is doing the work).
- Completed **subcontractor form** when applicable.