

REPLACEMENT WINDOWS GUIDE

The replacement of frames, sashes and glazing (glass) is considered a window replacement. Glass only replacements in an existing sash and frame do not require a permit. Window replacement is reviewed and inspected to assure safe emergency egress is maintained and the provisions of the current energy codes are complied with.

Building permits for window replacements expire 180 days from the date on the permit. No change to the approved plans is authorized without prior written approval by the code official and only the construction indicated on the attached plans is authorized by the issuance of this permit. This guide is not a substitute for any Village Ordinances or related documents, but is intended to supplement their use. Always consult the appropriate Village Ordinances for detailed information.

IN ORDER FOR THE BUILDING DEPARTMENT TO PROCESS YOUR APPLICATION, THE FOLLOWING DOCUMENTS MUST BE SUBMITTED :

- Completed building permit application.
- Homeowner's Association approval letter if applicable.
- The opening size of the existing window and the opening size of the replacement window. Windows for basement egress and bedrooms with minimums illustrated in figure 1.
- The U factor value of the window. Manufacture will provide information as illustrated in figure 2.
- A readable drawing indicating the location within the building and other pertinent information such as stairs, tubs, and doors. Also detail drawing of headers and stud support for new or enlarged windows.

Required Inspections:

1. Plan review and rough framing when window size is increased.
2. Final inspection – **DO NOT REMOVE** factory labels until approved by the Village inspector.

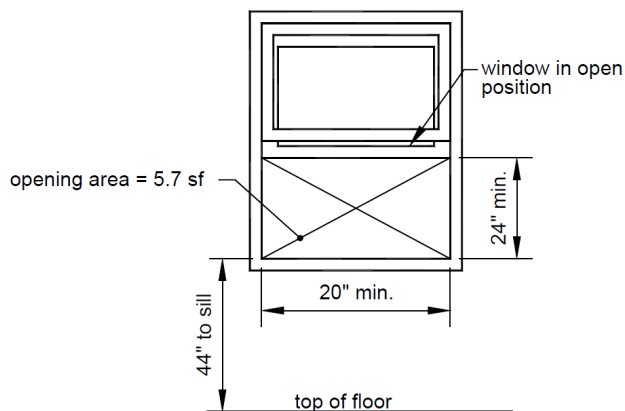

Figure 1

| | |
|---|-----------------------------|
|  World's Best Window Co. Millennium 2000+ Vinyl-Clad Wood Frame Double Glazing • Argon Fill • Low E Product Type: Vertical Slider | |
| ENERGY PERFORMANCE RATINGS | |
| U-Factor (U.S./I-P) | Solar Heat Gain Coefficient |
| 0.30 | 0.30 |
| ADDITIONAL PERFORMANCE RATINGS | |
| Visible Transmittance | Air Leakage (U.S./I-P) |
| 0.51 | 0.2 |
| <small>Manufacturer stipulates that these ratings conform to applicable NFRC procedures for determining whole product performance. NFRC ratings are determined for a fixed set of environmental conditions and a specific product size. NFRC does not recommend any product and does not warrant the suitability of any product for any specific use. Consult manufacturer's literature for other product performance information. www.nfrc.org</small> | |

Figure 2

CALL THE BLDG. DEPT AT 847-546-0963 FOR INSPECTIONS